



Phone: 877-770-5862

www.PrecisionLiftIndustries.com

## **PLANNING GUIDE OUTDOOR ELEVATOR ODE-500**

**This planning guide contains general information on the most popular and standard elevator configurations; and NOT all elevator configurations are shown. This guide has been created to assist in the planning and design of a home elevator for a private residence. This guide is not intended to provide specific information, be used as an owner's manual, or as the only source of preparation for a future elevator installation. Specific questions or concerns should be addressed with a PLI factory sales representative or local authorized dealer. Custom layouts are always available at no charge.**

### **Overview:**

Precision Lift Industries, LLC builds high quality residential elevators and vertical platform lifts that are designed with the perfect blend of performance and simplicity. Our residential and outdoor elevators are the perfect solution for new construction and retro fit projects. The winding drum machine provides an energy efficient, smooth, and reliable ride quality without using any hydraulics.

**Space saving design:** The tower on the outdoor elevator is specifically designed to hold all the components of the elevator drive system and take up minimal space while still maintaining a finished look. This includes the drum motor and gear box as well as the controller box.

**Technologically Advanced:** Our elevators use only CNC cut and folded interlocking sling components. When combined with a high quality motor / gearbox with the latest VVVF drive microprocessor controls, it provides years of reliable service.

**Flood zones / Coastal environments:** Our facility is located along the Florida Gulf Coast, and we have seen firsthand the damages that flooding and major storms can cause. The Outdoor Elevator is designed for coastal areas by utilizing high grade aluminum components throughout the elevator design. It is important to understand, that unlike most elevators on the market, these elevators have essentially only the rails at the bottom landing when parked at the top floor. There is no pumping unit, chains or counter weights to rust or become damaged over time.





Phone: 877-770-5862

www.PrecisionLiftIndustries.com

<b>THE OUTDOOR ELEVATOR</b> Specifications	
MODEL	ODE-500
CAPACITY	500 LBS
SPEED	25 FPM (Nominal)
DRIVE	OVERHEAD WINDING DRUM GEAR MOTOR
SAFETIES	INSTANTANEOUS TYPE "A" SLACK CABLE W/UNDER PAN PRESSURE PLATE
DOOR LOCKS	HONEYWELL RELIALIGN ELECTROMECHANICAL INTERLOCKS
OPERATION	CONSTANT PRESSURE
FINISH	MILL FINISH ALUMINUM 5052 & 6061 WITH POWDER COAT OPTIONAL
ELECTRICAL REQUIREMENTS	CONTROLLER COMES EQUIPPED WITH A 120VAC PLUG/PIGTAIL. REQUIRES A DEDICATED CIRCUIT, 120VAC, 20AMP OUTLET WITHIN SIGHT OF THE LIFT. FOR JURISDICTIONS WHICH REQUIRE THE CONTROLLER TO BE HARDWIRED, CUT CORD END AND HARD WIRE INTO APPROPRIATE DISCONNECTING MEANS. CORD MAY ALSO BE REMOVED AND REPLACED WITH APPROPRIATE WIRE SUPPLIED BY OTHERS.
CONTROL SYSTEM	PLC, RELAY, VFD MOTOR CONTROLLER, PLUG'N'PLAY FIELD WIRING
SUSPENSION	2 X AIRCRAFT GRADE STAINLESS STEEL CABLES 1/4" IN DIAMETER
CODE	AMSE 18.1.5-2014

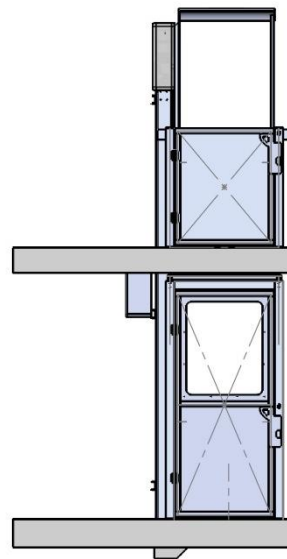
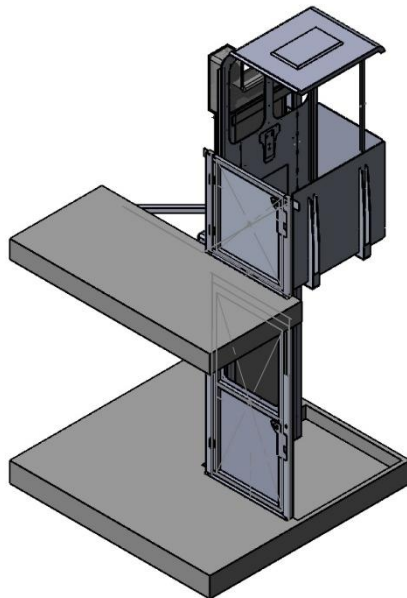



**PRECISION LIFT**  
INDUSTRIES, LLC

Phone: 877-770-5862

www.PrecisionLiftIndustries.com

### Typical Outdoor Elevator Application:

TRIANGLE BRACKET  
ATTACHES TOWER TO  
TOP LANDING FACE.

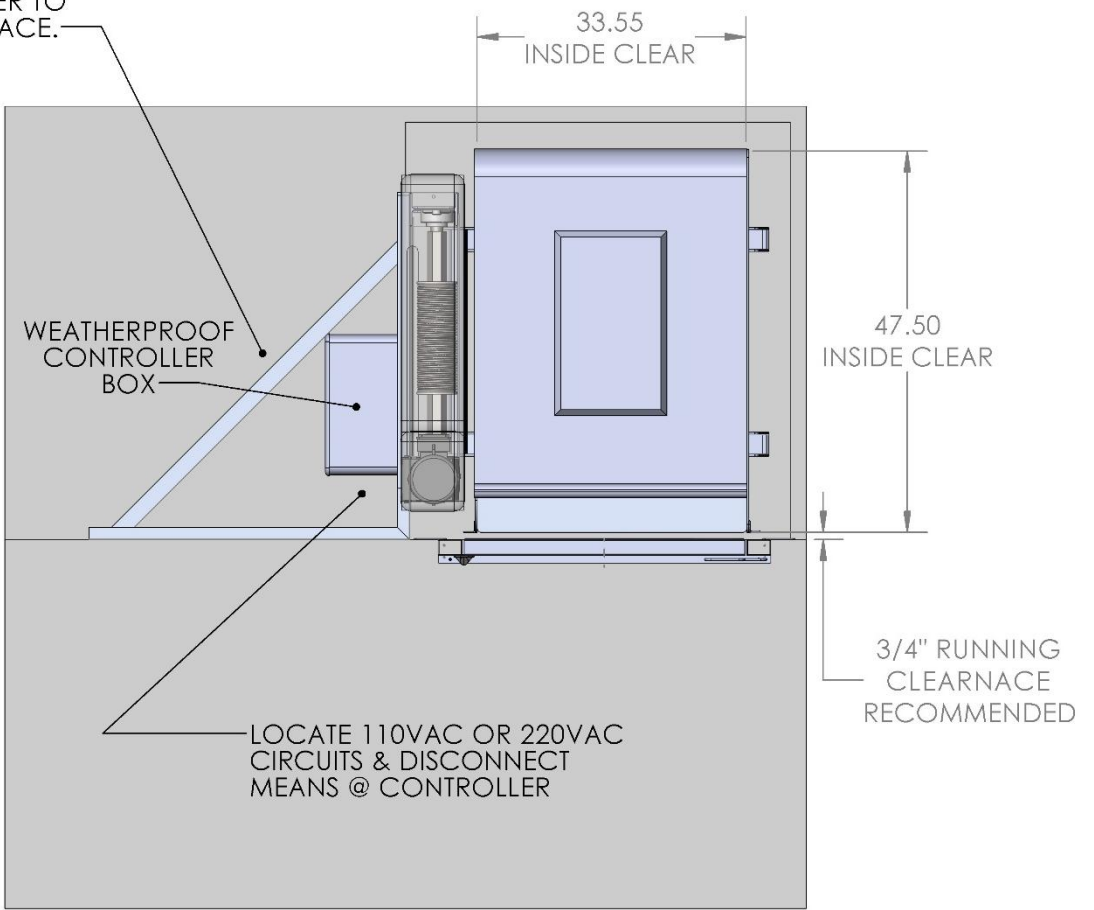



PRECISION LIFT  
INDUSTRIES, LLC

Phone: 877-770-5862

www.PrecisionLiftIndustries.com

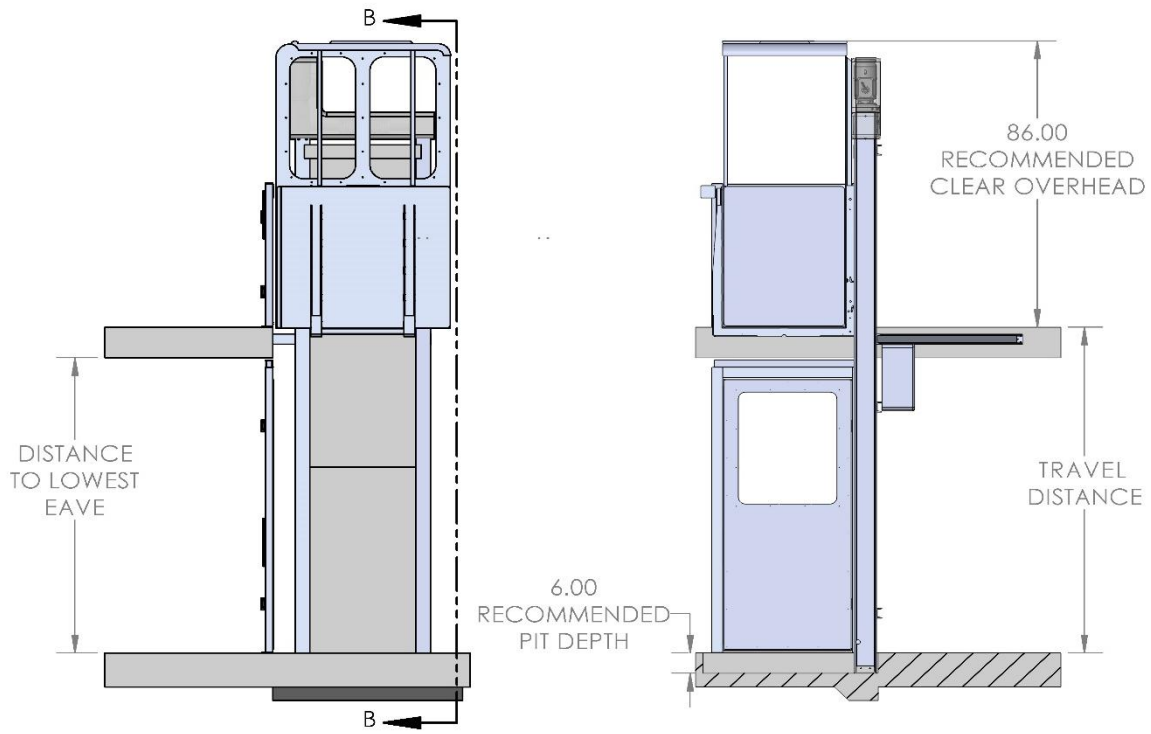

SECTION B-B  
SCALE 1 : 40

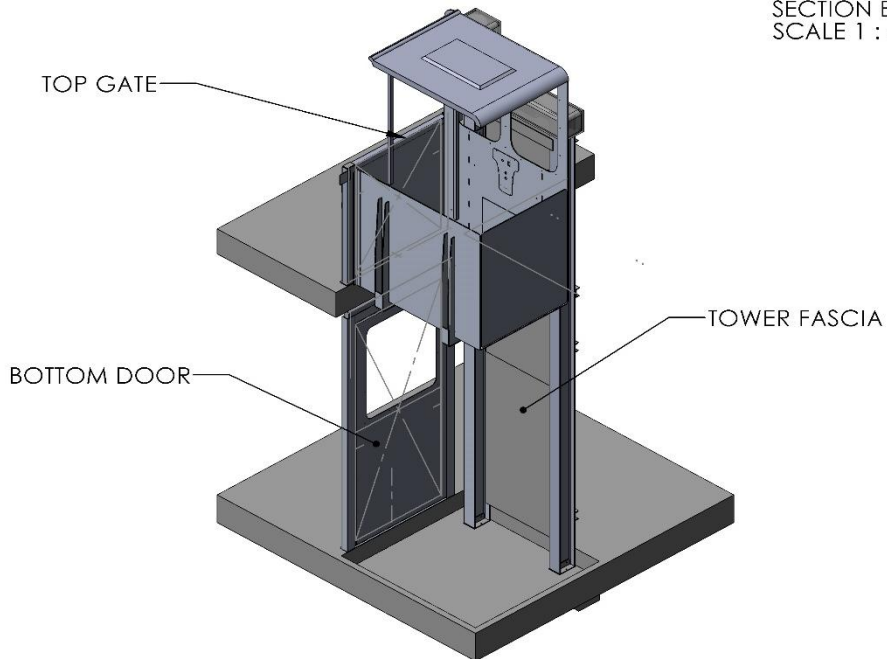



PRECISION LIFT  
INDUSTRIES, LLC

Phone: 877-770-5862

www.PrecisionLiftIndustries.com

## TOWER ANCHORING DETAIL

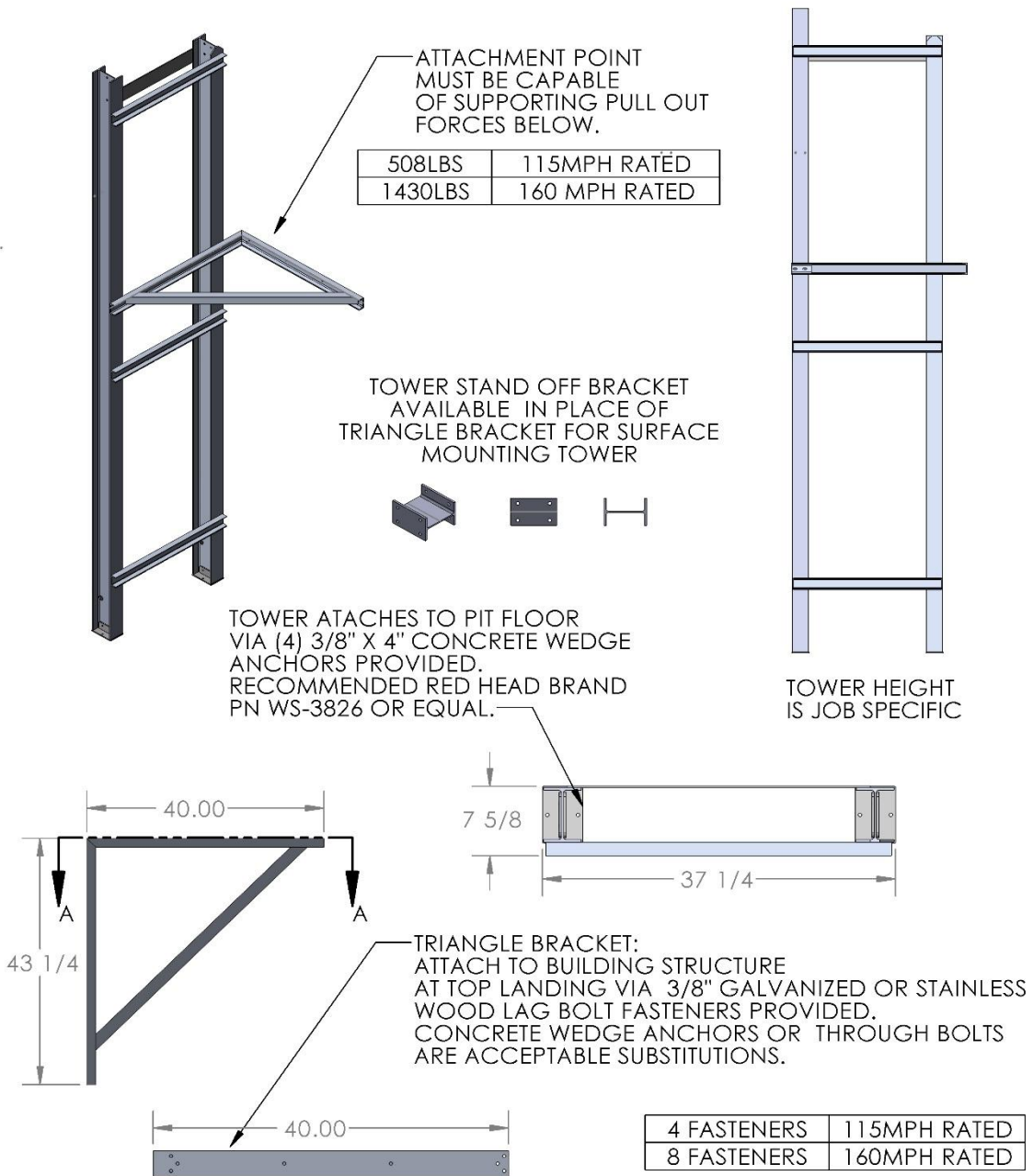

SECTION A-A  
SCALE 1 : 16



### Typical Door Configuration:

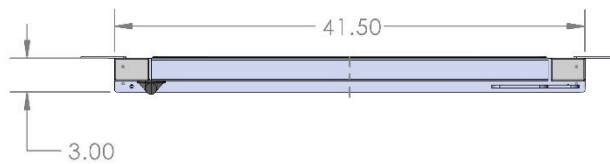
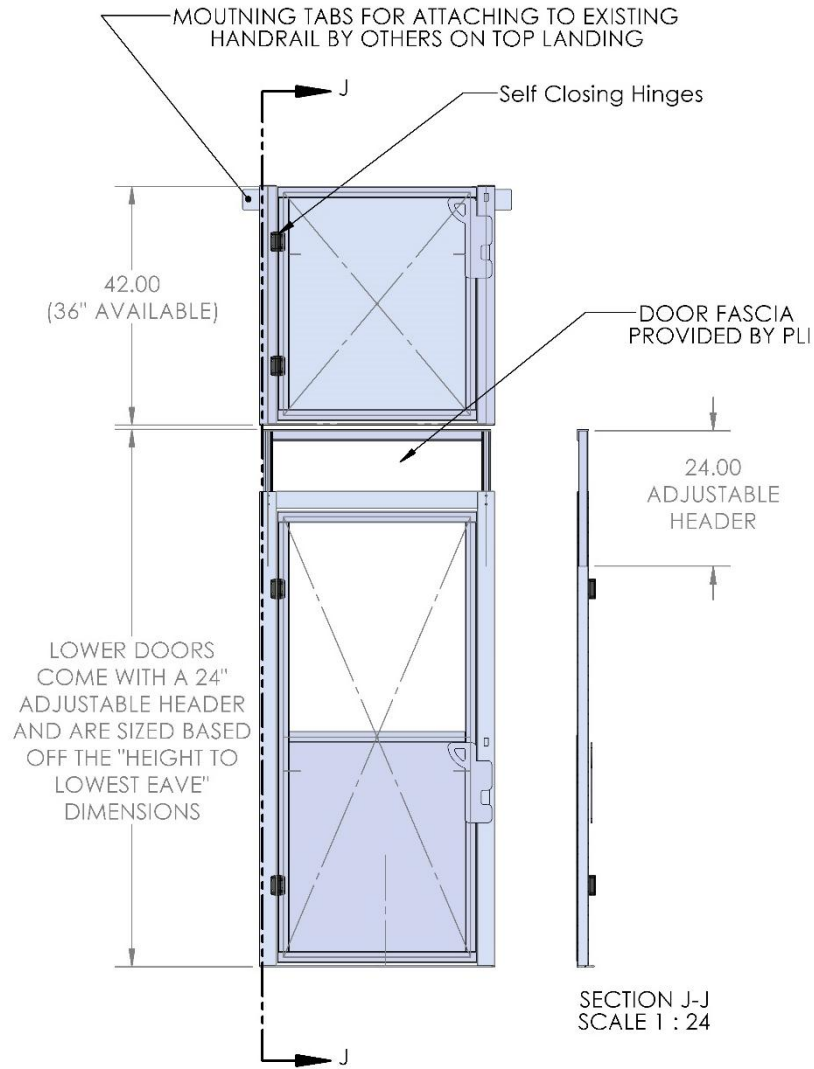



**PRECISION LIFT**  
INDUSTRIES, LLC

Phone: 877-770-5862

www.PrecisionLiftIndustries.com

### PIT DEPRESSION OPTION

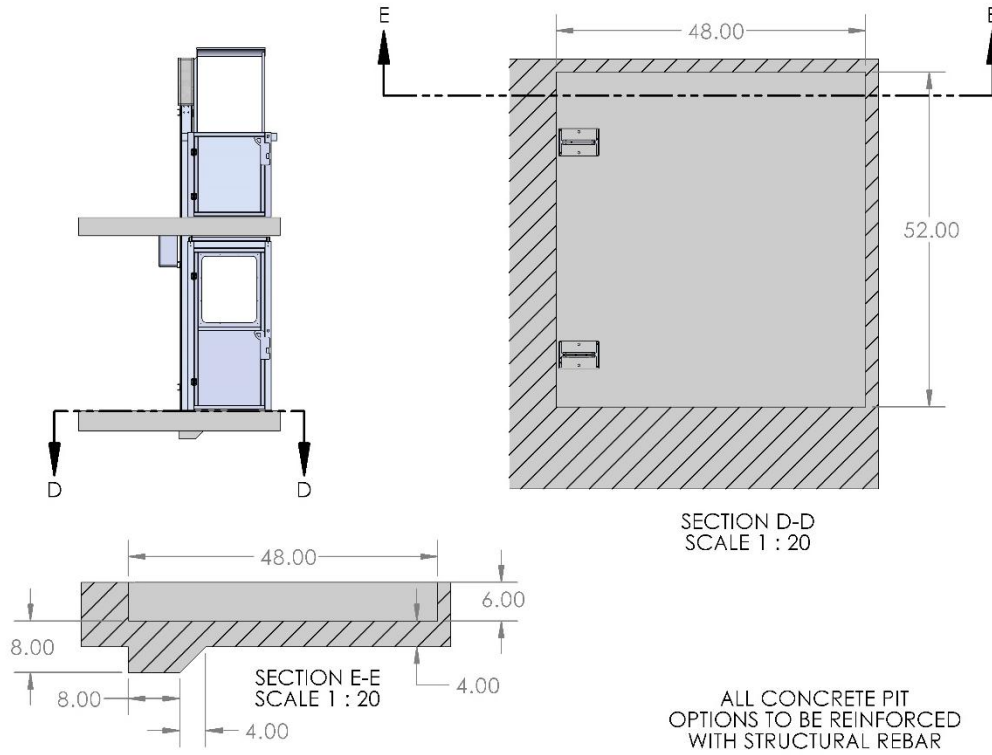

### PIT FOOTER OPTION

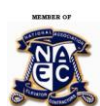
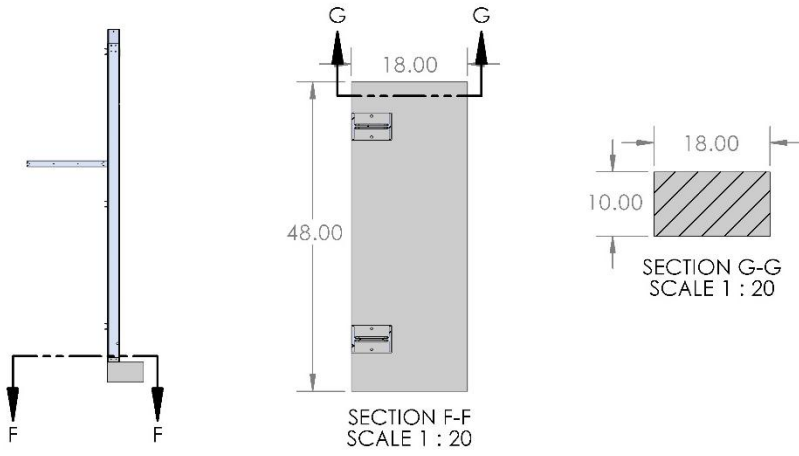



Phone: 877-770-5862

www.PrecisionLiftIndustries.com

**Pit:**

A reinforced pit recessed a minimum of 6" from the bottom landing must also be provided. The dimensions of the pit must be a minimum of 52" deep by 48" wide standing at the future entry side of the pit. If a reinforced pit cannot be provided, a 6" ramp can be provided leading up to the bottom door entry.

It is our recommendation that the pit floor be structurally adequate to hold approximately 3,800LBS as all forces from the lift are transferred down to the pit floor.

**Electrical Requirements:** A lockable and fusible disconnect should be installed with (1) 110v single phase 20 amp service. Disconnect should be located where controller will be installed.

**Work by others:**

- Removal / installation of existing handrail at second floor.
- Provide a 110VAC Means of disconnect at tower base.
- Provide proper sized concrete pad with pit or ramp.

Call 1-877-770-5862 with any questions and we will be happy to guide you through the process.







Phone: 877-770-5862

www.PrecisionLiftIndustries.com

## **THE OUTDOOR ELEVATOR WARRANTY**

Precision Lift Industries, LLC will repair or replace, at our discretion, any part or component, or any defects in materials or workmanship, which fail or occur under normal private residence use during the first 2 years from the date of shipping.

Damages or failures which occur due to misuse, shipping, construction use, vandalism, and acts of god (including but not limited to lightening, flood, fire, wind damages) are not covered by this warranty. Damages or failures which occur during installation and/or result from improper installation are not covered by this warranty. Labor to repair/install replacement parts is not covered by this warranty. Shipping of replacement parts is not included in this warranty. Construction use is defined as use of the elevator by any contractor, subcontractor or individual before final inspection of the elevator or final acceptance from the end user/purchaser. Upon written notice of a warranty claim, Precision Lift Industries, LLC will correct the problematic part/component within a reasonable amount of time. Parts or components in stock shall be shipped within 1 week of the warranty claim. For parts/components which are not in stock or require fabrication, a reasonable lead time will be quoted to the party submitting the warranty claim, and the part/component will be shipped once the part/component is completed.

**THE OUTDOOR ELEVATOR** comes with a limited lifetime corrosion warranty. Precision Lift Industries will repair or replace (at our discretion) any component (excluding the items listed below) which fails as a direct result of corrosion. Labor to replace or install the components is not included.

Corrosion warranty excludes drum, shaft and machine assembly, controller assembly, limit switches. Includes tower and complete carriage assembly. Paint is not covered by this warranty. Water Damage to the controller caused by improperly sealed field connections (incoming power line) is not covered under the warranty.

If you have a warranty claim, promptly submit the claim, in writing, to Precision Lift Industries, LLC via email, mail, or fax. Include the job name, number and description of the problem. Signed service orders/tickets from the elevator service company detailing the troubleshooting method used to determine the defective part may be required (at our discretion) for certain warranty claims. Upon receipt of the claim, we will contact the party submitting the claim and advise the status of the claim. Precision Lift Industries, LLC reserves the right to request/require more detailed information and/or troubleshooting prior to processing a warranty claim.

